



Bellows Type Pump Connector Installation Instructions

STORAGE:

1. Store expansion joints in a dry/cool location such as a warehouse.
2. Store flange face down on a pallet or wooden platform.
3. Do not store other heavy items on top of expansion joint (s).
4. Ten-year shelf life can be expected with ideal conditions.

HANDLING:

Do not lift with ropes or bars through the bolt holes. If lifting through the bore, use padding or a saddle to distribute the weight. Do not let expansion joints sit vertically on the edges of the flanges for any period of time.

SERVICE CONDITIONS:

Make sure the expansion joint rating for temperature, pressure, vacuum movements and selection of elastomeric materials match the system requirements. Contact the manufacturer if the system requirements exceed those of the expansion joint selected.

ALIGNMENT:

Expansion joints are not designed to make up for piping misalignment errors. Pipe misalignment should be no more than 1/8" in any direction.

ANCHORING:

Keflex™ vibration absorbers and flexible pump connectors must have the protection of adequate anchoring against the internal and thrust pressures of the media to prevent damage. Usually generic pump connectors are not required to absorb thermal pipe growth; however, bellows type pump connectors do have that capacity as they are basically expansion joints. Their main function is to contain all vibration in an area near to its source and to prevent "whipping" of adjacent piping. Anchoring must be installed as close to the outboard end of the connector as possible, with the terminal equipment serving as the opposite anchor. The outboard anchor must prevent pipe movement in any direction, as the degree of deflection movement cannot always be predicted. Hangers or pipe pedestals cannot be considered to be anchors as they offer no restriction against side or end motion.

When designing an anchor for a Keflex™ Bellows Type Flexible Pump Connector, consult the internal thrust force table from the Multi-ply Bellows Type Pump Connector catalog. The weight of piping, valves, and media, as well as the resistance of the piping to deflection, must sometimes be included as part of the design weight and strength of an anchor.

Anchors are required whenever a piping system changes direction. Expansion joints should be located as close as possible to anchor points. If an anchoring system is not used, it is recommended that control rods be installed on the expansion joint to prevent excessive movements from occurring due to pressure thrust of the line.

PIPE SUPPORT:

Piping must be supported so expansion joints do not carry any pipe weight.

MATING FLANGES:

Install the expansion joint flange against the mating pipe flanges and install bolts so that the bolt head is against the expansion joint flange. Bolts should be installed from the bellows side (so that the bolt heads are adjacent to the bellows) to insure that the bolts do not interfere with the bellows during periods of compression. Flange-to-flange dimensions of the expansion joint must match the required opening.

Make sure mating flanges are clean and are matched to the type supplied with the expansion joint. Gaskets of appropriate material, size and temperature ratings must be used in all flange-to-flange type installations.

BOLT TORQUE:

Tighten bolts in stages by alternating around the flange. Never tighten an expansion joint to the point that there is metal-to-metal contact between the expansion joint flange and the mating flange.



Bellows Type Pump Connector Installation Instructions

ADDITIONAL TIPS:

1. Insulation or thermal blankets over a metal expansion joint should be supplied by the expansion joint manufacturer to preclude the use of corrosive chloride bearing insulation materials. Insulation should be made removable to permit easy access to the flange area, to check bolting.
2. Do not weld in the near vicinity of a non-shrouded expansion joint without protecting the expansion joint from damaging weld splatter.
3. If an expansion joint is to be installed underground, or will be submerged in water, contact the manufacturer for specific guidelines.
4. Consider ordering a spare expansion joint. The cost of downtime of a critical expansion joint far exceeds the cost of a spare unit placed and protected in reserve on-site.

WARNING: Failure to install according to instructions, or any evidence of exceeding ratings will automatically void warranty.

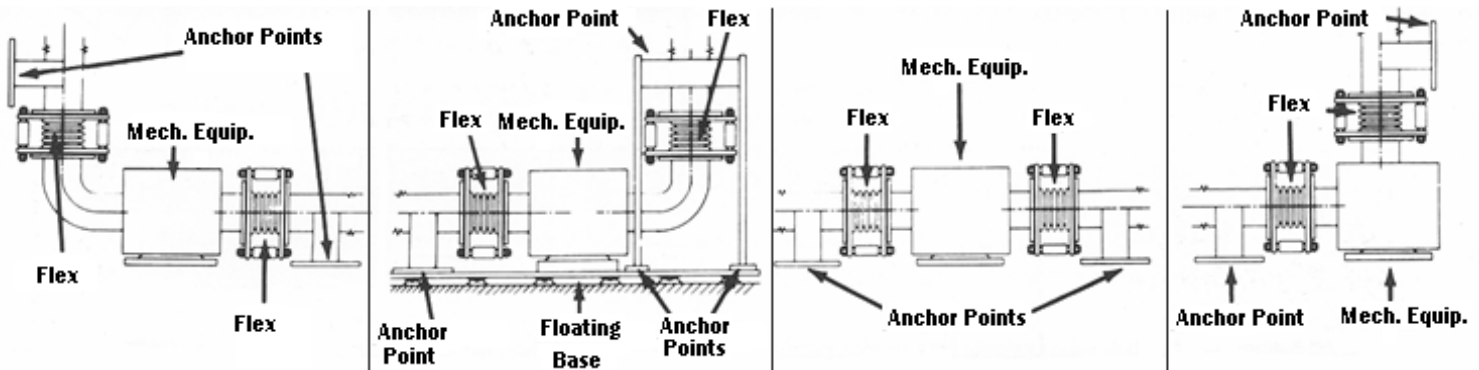

PIPE GUIDES—SPACING DIAGRAM

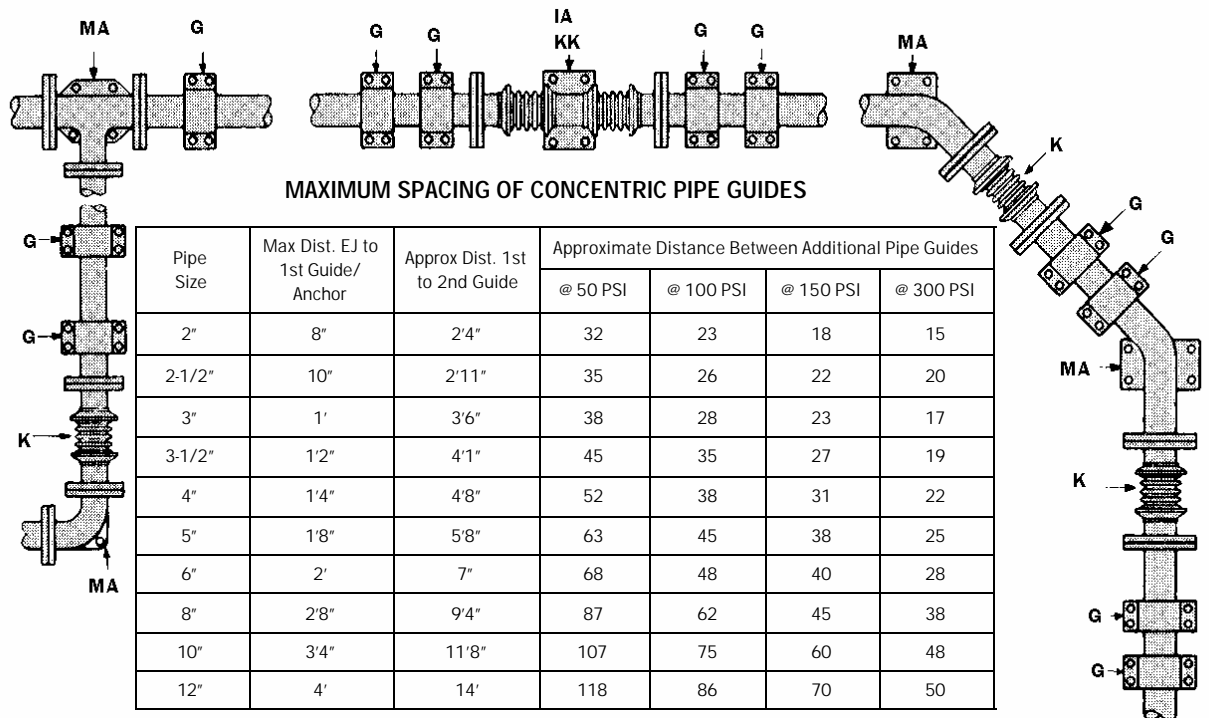

Note: All guides are shipped unassembled to save field labor time.